

AGENDA
City of Monona Landmarks Commission
Monona City Hall
5211 Schluter Road, Monona, WI
Remote Teleconference Meeting via ZOOM
Wednesday November 11, 2020
4:30 PM

NOTICE OF ELECTRONIC MEETING

Due to the current state of emergency because of the COVID-19 pandemic, this meeting will be conducted via electronic videoconferencing/teleconferencing. As such, it is likely that some or all members of, and a possible quorum, may be in attendance via electronic means and not physically present. In accordance with Wisconsin law, the meeting will remain open to the public. The public may still attend in person at the location stated in this agenda. However, due to the need to maintain social distancing in accordance with Emergency Order #12 (Safer At Home Order) and the limited physical space available, the public is encouraged and requested to also attend via electronic means. Directions to do so are listed at the bottom of this agenda. Upon reasonable notice, the needs of disabled individuals will be accommodated through auxiliary aids or services. For additional information or to request this service, contact Joan Andrusz at 608-222-2525.

1. Call to Order
2. Roll Call
3. Approval of Minutes of October 14, 2020
4. Appearances
5. Unfinished Business
 - A. Discussion and Possible Action for Springhaven Pagoda Roof Repair RFP
6. New Business
 - A. Staff Updates
 - i. Stone Bridge Park Improvements
7. Upcoming meetings – December 9, 2020 and January 13, 2021
8. Adjournment

DIRECTIONS TO ATTEND MEETING ELECTRONICALLY

You may attend via videoconference by downloading the free Zoom program to your computer at <https://zoom.us/download>. At the date and time of the meeting log on through the Zoom program and enter Meeting ID: 898 1915 2648.

You may attend via telephone conference by calling the following phone number:

PHONE NUMBER: 1-301-715-8592 / MEETING ID: 898 1915 2648, FOLLOWED BY #

Please Mute Your Phone When Not Speaking To Ensure Best Possible Audio Quality.

NOTE: Upon reasonable notice, the City of Monona will accommodate the needs of disabled individuals through auxiliary aids or services. For additional information or to request this service, contact Joan Andrusz at (608) 222-2525 (not a TDD telephone number), FAX: (608) 222-9225, or through the City Police Department TDD telephone number 441-0399. The public is notified that any final action taken at a previous meeting may be reconsidered pursuant to the City of Monona ordinances. A suspension of the rules may allow for final action to be taken on an item of New Business. It is possible that members of and a possible quorum of members of other governmental bodies of the municipality may be in attendance at the above stated meeting to gather information or speak about a subject, over which they have decision-making responsibility. Any governmental body at the above stated meeting will take no action other than the governmental body specifically referred to above in this notice. Agenda Posted 11/05/2020 on the City Hall, Library, and Community Center bulletin boards and on the City of Monona's website, mymonona.com.

MINUTES
City of Monona
Landmarks Commission
Wednesday October 14, 2020

Chair Goforth called the meeting of the Monona Landmarks Commission to order at 4:37 PM.

Present: Chair Kristie Goforth, Ms. Mary Murrell, Mr. Rick Bernstein, and Ms. Rebecca Holmquist

Absent: Ms. Branda Weix, Ms. Anne Wellman and Mr. Erik Lincoln

Also Present: Douglas Plowman, City Planner

Approval of Minutes

A motion by Mr. Bernstein, seconded by Ms. Holmquist, for the approval of the minutes of August 12, 2020 carried with no corrections.

Appearances

There were no appearances.

Unfinished Business

A. Updates regarding Stone Bridge Park Design

Planner Plowman provided an update to the Commission. A number of meetings have taken place since the last Landmarks meeting. A joint meeting with the Parks Board was held where public input and discussion on the plans was solicited including how they incorporate the Pagoda. A second Parks Board meeting took place where revisions were made to the design. Finally, a number of Landmarks members met with Parks Director Anderson on site, and discussed the Pagoda and the surrounding area. This included discussion of the slope behind the Pagoda, as well as the extent of the excavation that may occur. Suggestions were for an equal distance all around the Pagoda, with more room from the slope. Stonework in the lower sections, with terracing and native plantings on the slope towards the top. These are still to be finalized, but the feedback will be taken back to the design team.

Chair Goforth discussed the design of the spring in Lodi, as shared by Mr. Lincoln, and how design queues could be taken for the Pagoda. The water is directed efficiently, but it doesn't abut a shoreline as is the case with Stone Bridge Park. Mr. Bernstein supports a natural treatment for the area with effective landscaping. Planner Plowman will follow up with Parks Director Anderson to understand the next steps for the design process. Chair Goforth shared with the Commission that she will be proposing an amendment to the 2021 Capital Budget to limit the park redesign portion. Specifically, this will focus on the armored wall and retaining walls, which could save \$100,000. The Pagoda will remain a high priority with this proposal, but some of the additional walls could detract from the natural feel of the park. Ms. Holmquist asked if these changes would impact access to the Pagoda. The walkway should still access the Pagoda, but Chair Goforth specifically focused on the limestone walls leading to the shore instead.

New Business

A. Recommendation to Council on selection of National Register Consultant

Planner Plowman provided the Commission with an update and overview of the interview process that took place with assistance from other Commission members. There were four responses to the RFP, three of which wanted to proceed with the work. Interviews were held,

with assistance from Chair Goforth, Ms. Holmquist and Mr. Bernstein, and the panel were impressed by them all. Each consultant demonstrated significant knowledge in the subject area, as well as the necessary experience.

UWM-CRM had expertise with each of the building types in the RFP. This includes experience with school buildings in Milwaukee, as well as another Kohl's grocery store. The UWM does not charge profit for work with municipalities, and the proposal is at cost. Mr. Bernstein added that the project lead lives in Stoughton, so that will limit travel time. The second group was the Preserve group. They also proposed all six properties, there was different pricing for each property. Their opinion was that the school buildings would require the most research and time. They had good examples of previous work, which were complimentary to the City's list. They were also located in Milwaukee, and not having a local team member meant they would require more travel time. The cost was almost double the UWM proposal, and would require a budget request of Council to cover the difference. The skill level and expertise was very similar when compared with UWM. Ms. Holmquist said that the Preserve are a fantastic firm that do great work, but that she doesn't see the City spending the extra money. Mr. Heggland has specific ties to the two residential properties he bid, and has conducted over 180 successful National Register nominations. He has extensive experience in Monona, and has worked on other Landmark materials. Ms. Holmquist shared that initially her preference was for one consultant, but having interviewed the candidates, she thinks he would be a great fit for the houses, and UWM to assist with schools and commercial buildings.

A motion was made by Ms. Murrell, seconded by Ms. Holmquist, to recommend the award of National Register Consulting Services to Mr. Timothy Heggland for the two properties listed in his proposal, and to the University of Milwaukee CRM for the remaining four properties as listed in the RFP.

The motion carried.

There is the possibility that there be money left over from the CLG grant. There has been past discussion of how else to spend the money. Mr. Bernstein added that it would need to be an eligible activity, and it could go towards local landmark nominations or other mound groups in Monona that are still unregistered. There was also discussion of the possibility of adding a National Register plaque, and if this could be covered. Planner Plowman can check with the State to see what could be an eligible expense. UWM have experience with mounds, and have worked in Monona when infrastructure projects occur. Planner Plowman will contact the State Archaeologist again, as he is yet to hear next steps for the Panther Mound.

B. Staff Updates

i. Springhaven Pagoda RFP

Planner Plowman updated the Commission that the RFP document is currently being prepared as had been directed at the last meeting. The delay was caused by the proposal being reviewed by City Engineering Staff to ensure it was as complete as possible. The Commission requested that this be presented at their November meeting, and that Mr. Eagan be invited to join the meeting to answer any questions that may arise.

ii. San Damiano – City of Monona Purchase Agreement Update

Chair Goforth updated the Commission on the San Damiano purchase agreement that has been reached. The 2021 Capital Budget was also discussed which has \$50,000 in funds for conceptual planning, an appraisal of the property as well as archaeological services. Mr. Bernstein shared that the property was previously reviewed for National Register eligibility, and deemed ineligible. If the issues could be addressed it could become eligible, and also for tax credits. Ms. Holmquist added

that the previous nomination was for architecture (Criterion C), but that it could be eligible for historic significance (Criterion A).

Upcoming meetings

Upcoming meetings are scheduled for November 11, 2020 and December 9, 2020.

Adjournment

A motion by Ms. Holmquist, seconded by Mr. Bernstein, to adjourn carried. (5:27pm)

Submitted by,

Doug Plowman, City Planner

DRAFT

SPRINGHAVEN PAGODA - STONEBRIDGE PARK

NOVEMBER 11, 2020

RESTORATION MODEL



HISTORIC REFERENCE



SPRINGHAVEN PAGODA ca. 1890

LOCATION MAP

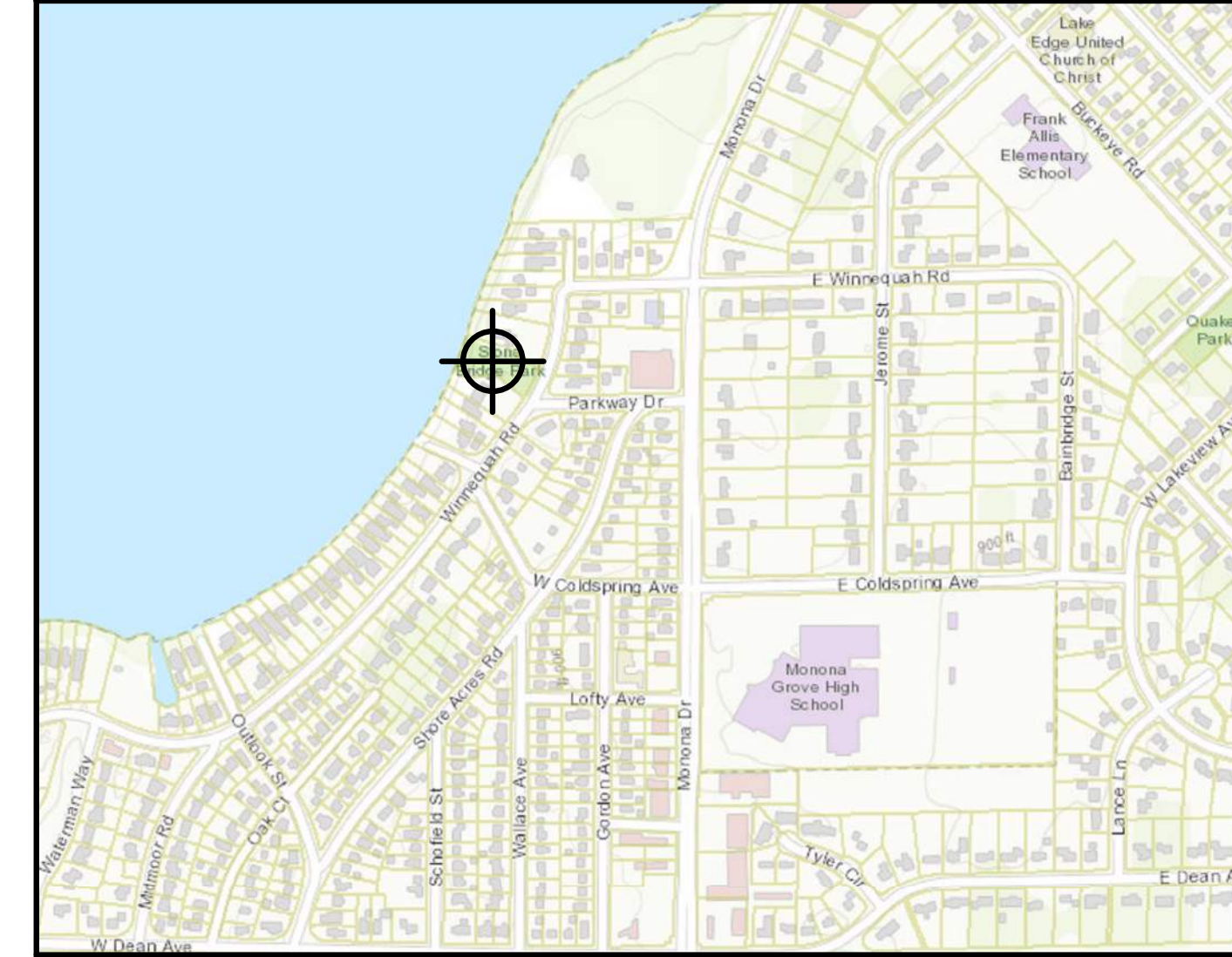

PROJECT ADDRESS
 STONEBRIDGE PARK
 INTERSECTION OF WINNEQUAH RD & PARKWAY DR
 MONONA, WI 53716

**ONE DESIGN &
 ENGINEERING**
 202 Ash St
 Cambridge, WI 53523
 608-577-0443
 www.onedesign.com

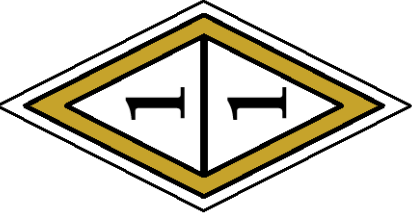

SPRINGHAVEN PAGODA - STONE BRIDGE PARK

Winnequah Road & Parkway Dr
 Monona, WI 53716

Sheet Title
COVER SHEET

Revisions:

Project #: 20-011
 Issued for: REVIEW
 Date: 11/11/2020

Sheet Number

T-1.0

SHEET LIST

SHEET	TITLE
A-1.0	EXISTING SITE PLAN
A-1.1	DETAILS
T-1.0	COVER SHEET

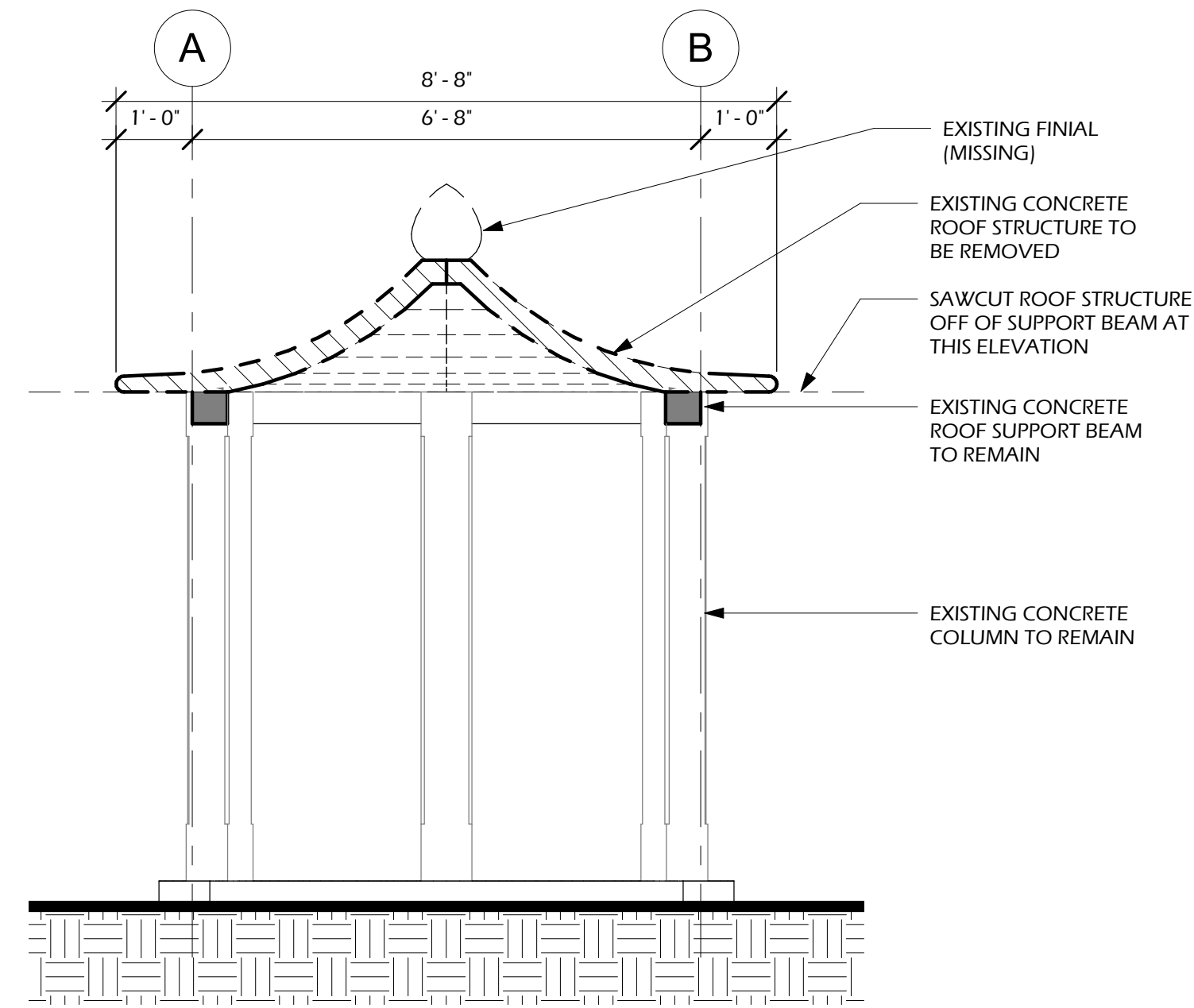

3 PAGODA CROSS SECTION
A-1.0 1/2" = 1'-0"

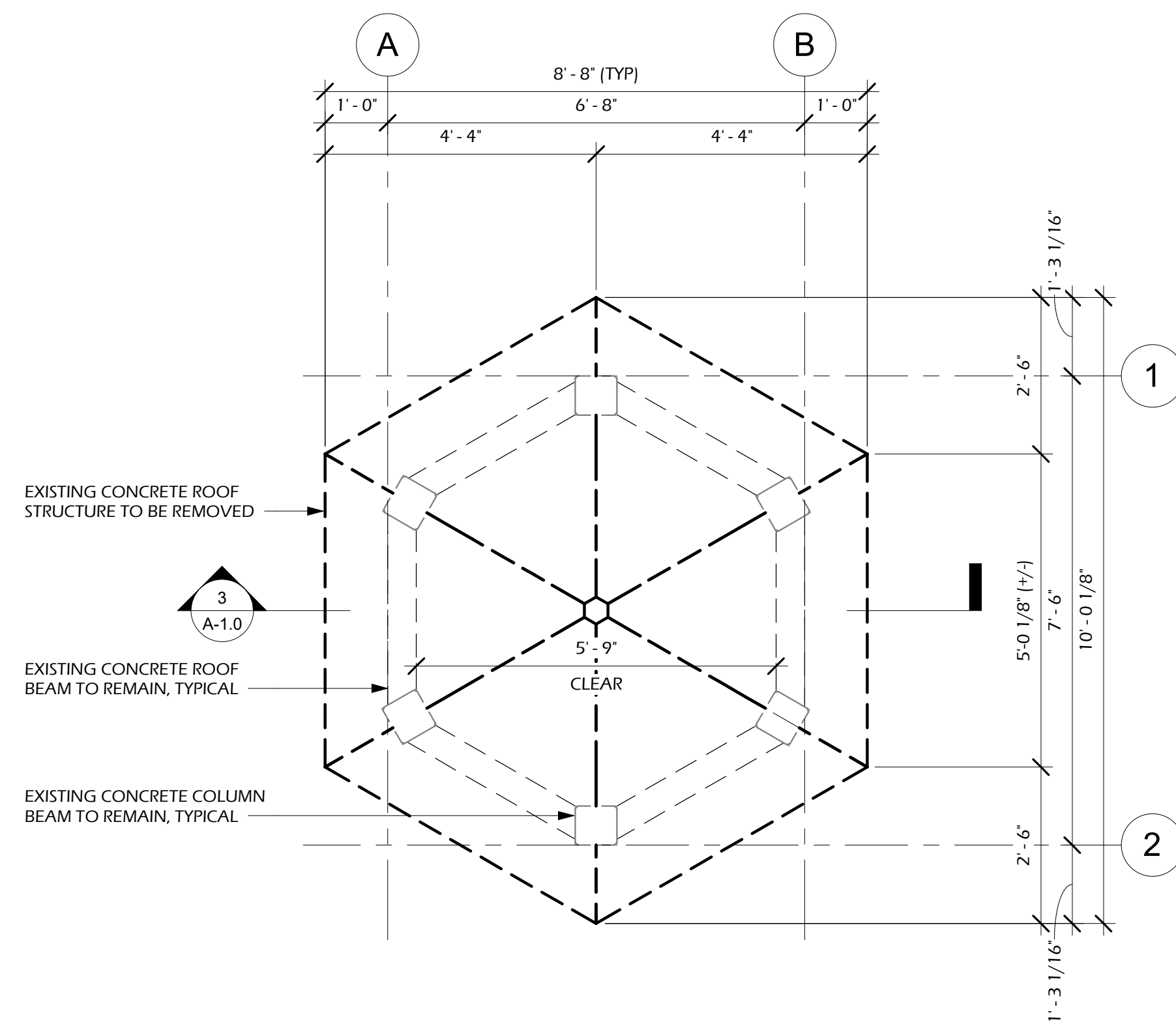

2 ENLARGED PAGODA PLAN
A-1.0 1/2" = 1'-0"

FOUNDATION NOTES

- DATUM ELEVATION 100'-0" = 950.50 FT @ WORKPOINT #1
- CONCRETE MIX DESIGN SHALL BE AS FOLLOWS:

MIX	F _c (28 DAY)	SLUMP	% AIR	W/C RATIO
ROOF	3,000 PSI	4" +/- 1"	6% +/- 1%	0.68
- REINFORCING STEEL TO BE ASTM A615, GRADE 60 STEEL
- NEW ROOF STRUCTURE TO HAVE A LIGHT SANDBLASTED FINISH.
- CONTRACTOR TO PROVIDE A CONCRETE SAMPLE FOR APPROVAL. MIX DESIGN FOR NEW ROOF STRUCTURE TO BE COLORED TO MATCH MATCHING OF EXISTING CONCRETE STRUCTURE.

PROJECT SCOPE

- PROJECT SCOPE IS LIMITED TO THE REMOVAL AND REPLACEMENT OF THE EXISTING CONCRETE PAGODA ROOF.
- THE EXISTING PAGODA COLUMNS AND SUPPORTING BEAMS ARE TO REMAIN IN PLACE.
- SAWCUTTING OF EXISTING ROOF STRUCTURE AT THE TOP OF EXISTING SUPPORT BEAMS WILL BE REQUIRED. SAWCUTTING OF ROOF TO BE FLUSH WITH TOP OF CONCRETE BEAMS AT OUTER FACE OF BEAMS.
- DECORATIVE FINIAL AT PEAK OF EXISTING ROOF STRUCTURE IS MISSING. A NEW CONCRETE FINIAL IS TO BE MADE AND INSTALLED AT NEW ROOF PEAK.
- CONCRETE MIXTURE USED FOR NEW ROOF STRUCTURE AND FINIAL TO MATCH EXISTING PERGOLA COLOR. CONCRETE PROVIDER TO FIELD MATCH COLOR OF PROPOSED CONCRETE MIXTURE WITH EXISTING PERGOLA.
- NEW ROOF STRUCTURE AND FINIAL TO RECEIVE A LIGHT SAND-BLAST FINISH TO MIMICK EXISTING PERGOLA FINISH.
- EXISTING PERGOLA STRUCTURE TO BE CLEANED AFTER CONSTRUCTION WORK IS COMPLETE AND PRIOR TO TURNOVER TO THE CITY. CLEANING SHALL BE PERFORMED BY POWERWASHING AND USE OF DETERGENT AND/OR CHLORINE BASED CLEANERS.
- RESTORATION OF SITE DAMAGED BY ERECTING EQUIPMENT OR OTHER DEVICES IS TO BE PROVIDED BY THE CONTRACTOR.

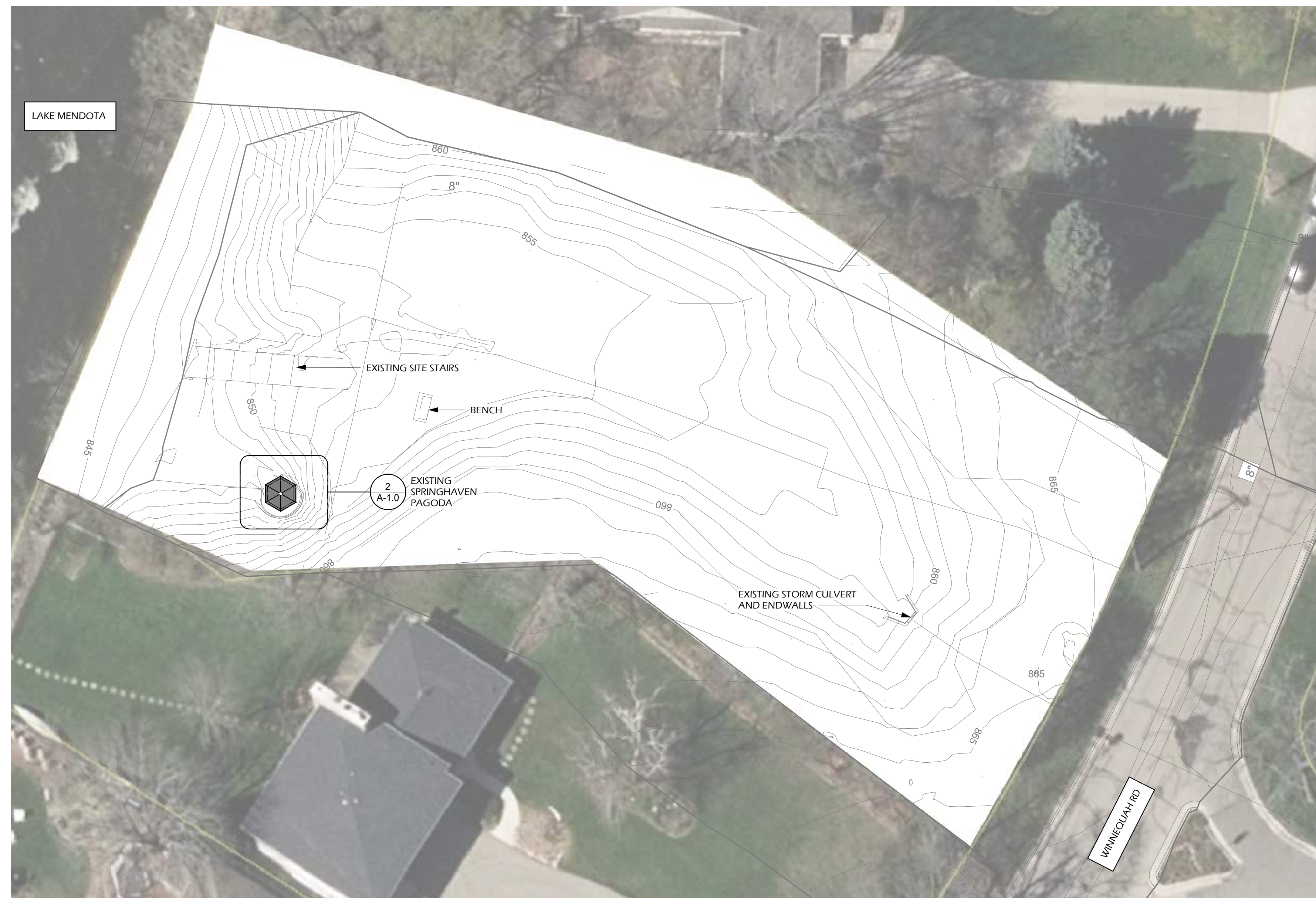

1 EXISTING SITE PLAN
A-1.0 1" = 20'-0"

Revisions:

Project #: 20-011
Issued for: REVIEW
Date: 11/11/2020

Sheet Number
A-1.0

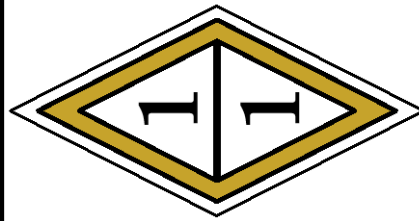

SPRINGHAVEN PAGODA - STONE BRIDGE PARK
Winnequah Road & Parkway Dr
Monona, WI 53716

Sheet Title
DETAILS

Revisions:

Project #: 20-011
Issued for: REVIEW
Date: 11/11/2020

Sheet Number

A-1.1

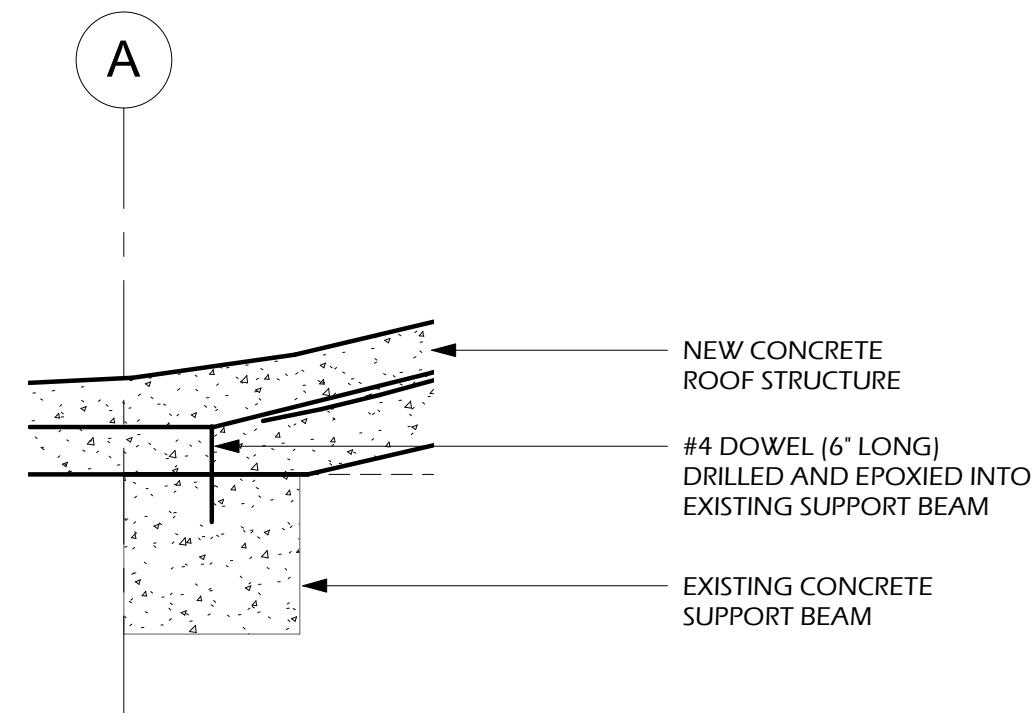
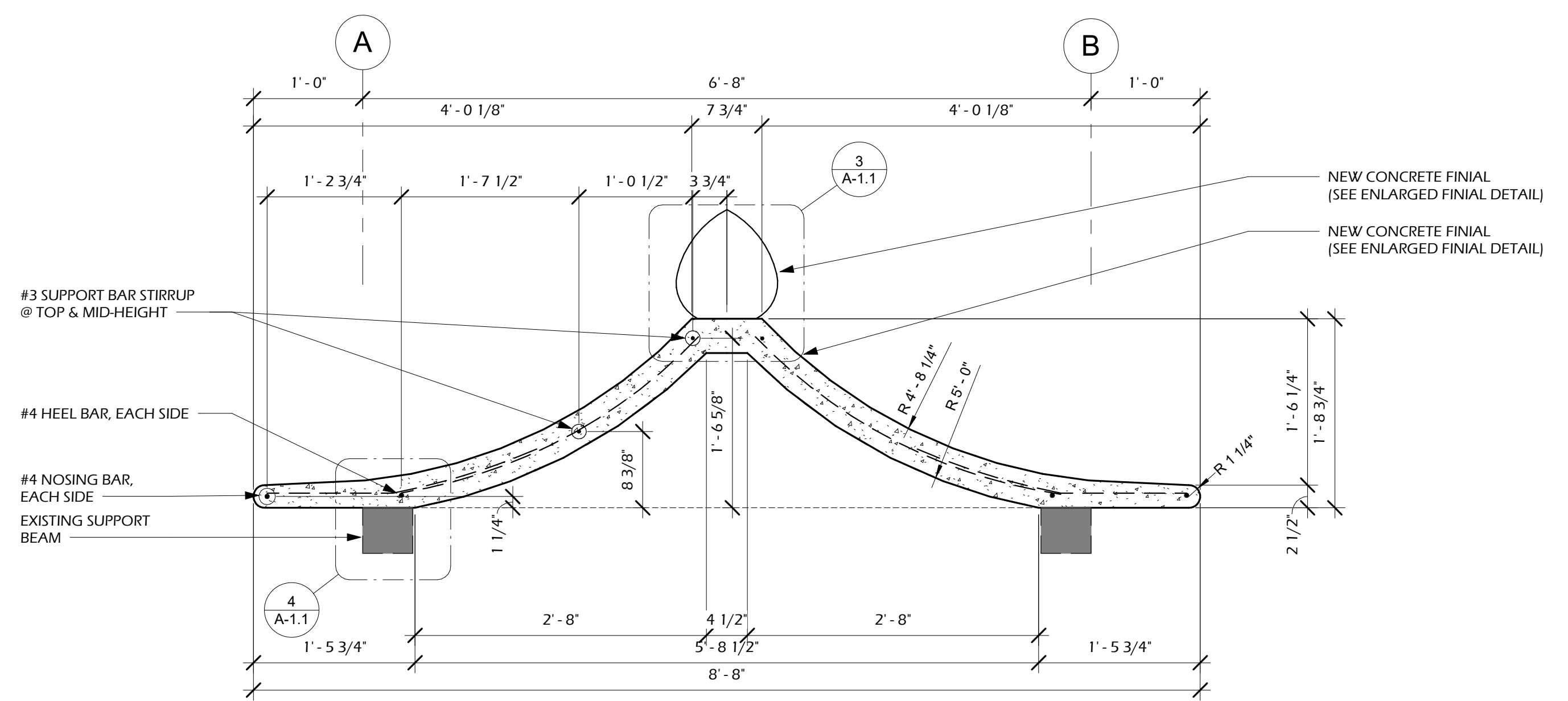
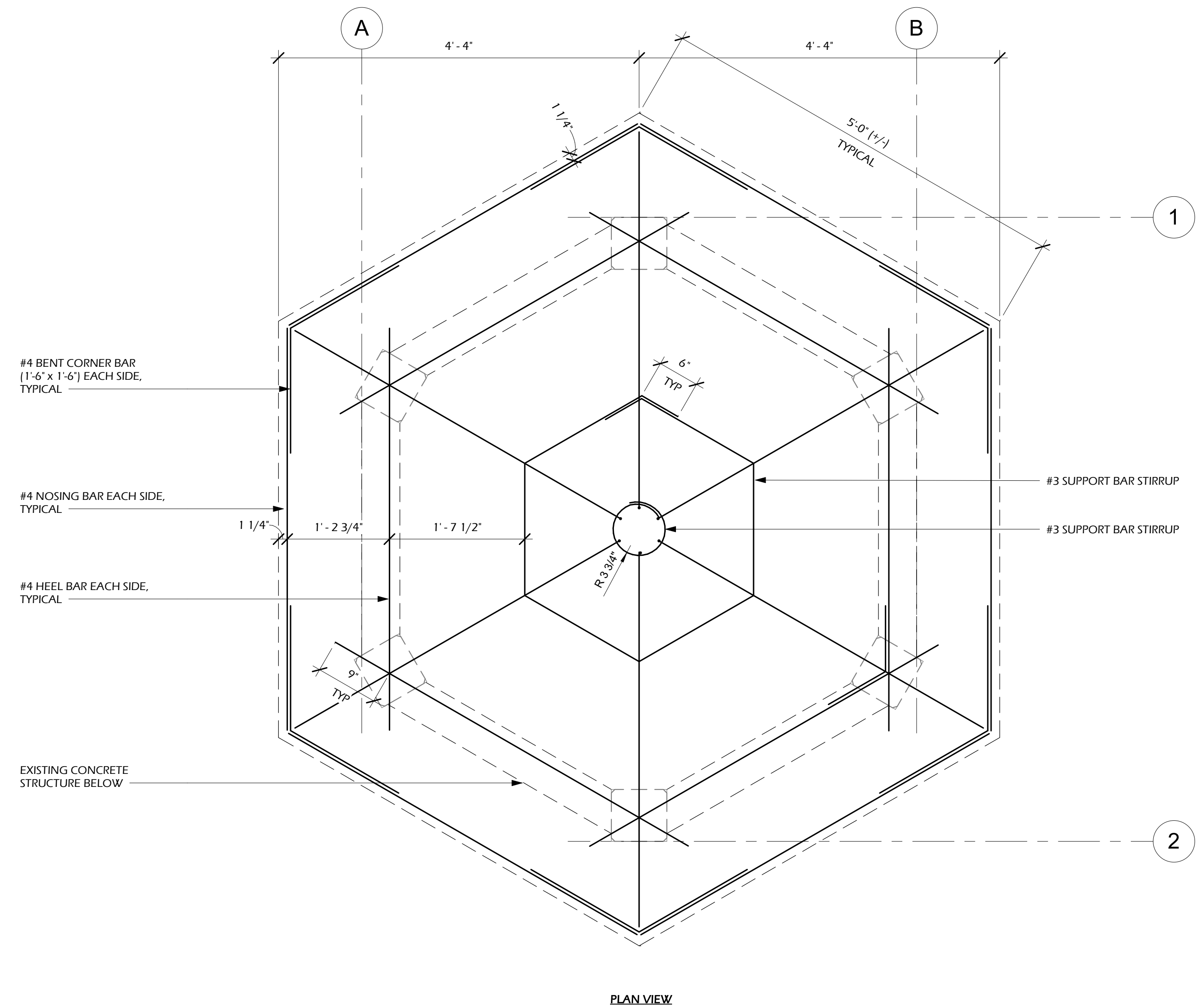

4
A-1.1 1:6
ROOF MOUNTING DETAIL

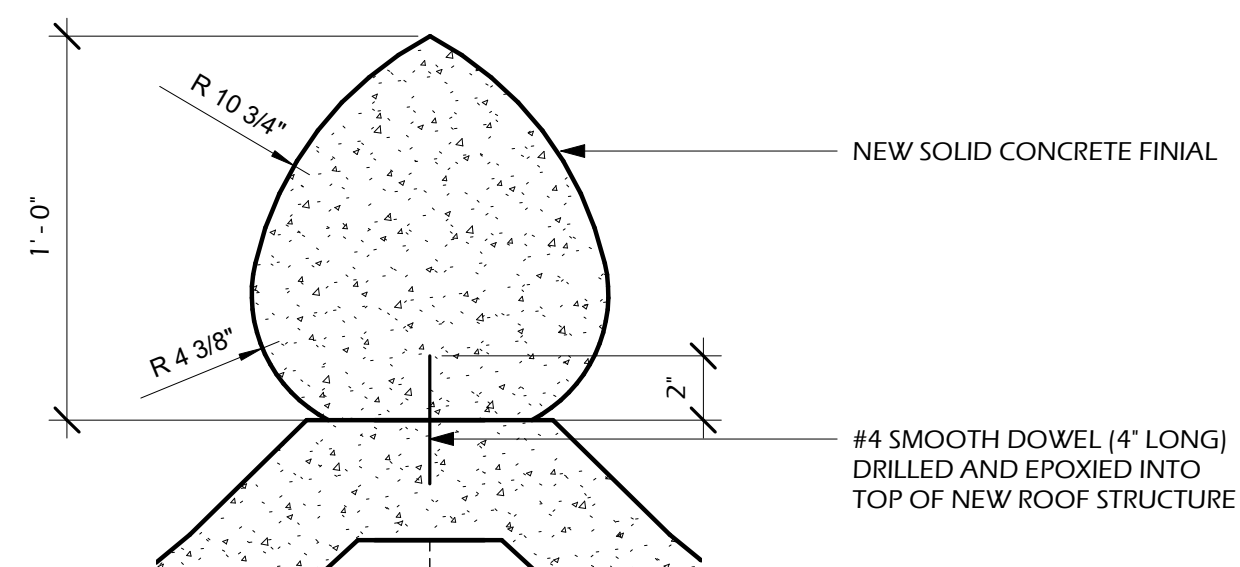

3
A-1.1 1:6
FINIAL DETAIL

1
A-1.1 1'-0"
NEW ROOF STRUCTURE SECTION

SPECIAL PROVISIONS

The work included in this project scope shall be in completed accordance with the plans. The scope items shall be described in the following section and executed according to construction documents and any referenced standards.

1 – Mobilization

Scope: This work shall include the cost of moving in equipment and supplies to the site, the establishment of necessary stockpiles, and moving the same off site.

Reference Standard: None.

Payment: This work will be measured and paid for at the contract lump sum price. This shall include compensation for furnishing, delivering, installing, maintenance, and removal of materials, and for all labor, equipment, and incidentals necessary to complete this item of work.

2 – Erosion Control

Scope: Land disturbance is not anticipated for the project. As such, Erosion Control measures are not included in the scope of the project.

Reference: Not Applicable

Payment: Not applicable.

3 – Demolition

Scope: This work consists of saw-cutting, removing, and disposing of the existing concrete pergola roof structure. Items include but are not limited to saw cutting, and tree protection and removing the existing pergola roof structure.

Payment: This work will be measured and paid for at the contract lump sum price. This shall include compensation for furnishing, delivering, installing, maintenance, and removal of materials, and for all labor, equipment, and incidentals necessary to complete this item of work.

4 – Pergola

Scope: This work consists of the removal and replacement of the existing pergola roof structure. Materials shall be provided and installed in accordance with the construction documents. The scope of work includes saw-cutting and removal of the existing concrete roof structure, forming pouring, and installation of a new roof structure with finial, and cleaning of the existing pergola structure to remain.

Payment: This work will be measured and paid for at the contract lump sum price. This shall include compensation for furnishing, delivering, installing, maintenance, and removal of materials, and for all labor, equipment, and incidentals necessary to complete this item of work.

5 – Restoration

Scope: This work consists of restoration of areas disturbed during the project and includes furnishing and installing topsoil; seeds, fertilizer, and mulch. This item also includes erosion matting on slopes greater than 5:1.

Reference:

Per WisDOT Section 625, 627, 628, 629, 630

SEED: Seed Mixture shall be WisDOT #40, per Section 630. Seed shall be free of non-seed debris and invasive weed species.

SPRINGHAVEN PAGODA – STONE BRIDGE PARK

Project No. 20-011

ESTABLISHMENT PERIOD: Contractor to maintain new turf areas until a substantial growth is observed and approved by the Owner or A/E. Any bare areas greater than 5" square shall be re-seeded as necessary until growth is acceptable.

Payment: This work will be measured and paid for at the contract lump sum price. This shall include compensation for furnishing, delivering, installing, maintenance, and removal of materials, and for all labor, equipment, and incidentals necessary to complete this item of work.